



Empowering your business, one transaction at a time.

Innovative payment solutions delivered with a personal touch.

Accept payment in-person or online with our innovative terminal solutions. Whether you need a stationary, wireless, mobile, or virtual terminal, a payment gateway, or software integration, ECS is the right choice for you.

Diverse Solutions for every scenario.



Lending

Lending your way to provide you with the instant capital you need.



ACH

Completely electronic, ACH transactions are efficient and low-cost.



ATM

Connect to all major ATM networks.



Merchant Cash Advance

Access the assets your business deserves.



Banking

Access our affordable rates and award-winning merchant services team.



Credit & Debit

Diverse range of credit and debit card processing solutions.



Remote Deposit Capture

No need to go to the bank to cash payment checks.



High-Risk

We're built to handle complex merchants, regardless of your industry.

To find out more [click here](#)

V200c and V400c

Installation Guide



V200c and V400c Installation Guide
© 2018 Verifone, Inc.

All rights reserved. No part of the contents of this document may be reproduced or transmitted in any form without the written permission of Verifone, Inc.

The information contained in this document is subject to change without notice. Although Verifone has attempted to ensure the accuracy of the contents of this document, this document may include errors or omissions. The examples and sample programs are for illustration only and may not be suited for your purpose. You should verify the applicability of any example or sample program before placing the software into productive use. This document, including without limitation the examples and software programs, is supplied "As-Is."

Verifone and the Verifone logo are registered trademarks of Verifone. Other brand names or trademarks associated with Verifone's products and services are trademarks of Verifone, Inc.

All other brand names and trademarks appearing in this manual are the property of their respective holders.

For Product warranty information, go to: www.verifone.com/terms.

Comments? Please e-mail all comments on this document to your local Verifone Support Team.

Verifone, Inc.

1-800-Verifone

www.verifone.com

Verifone Part Number DOC420-003-EN-C, Revision C



CONTENTS

| | |
|--|----|
| PREFACE | 5 |
| Audience | 5 |
| Organization | 5 |
| Related Documentation | 5 |
| Conventions and Acronyms | 6 |
| Document Conventions | 6 |
| Acronym Definitions | 6 |
| | |
| CHAPTER 1 | |
| Device Overview | |
| Features and Benefits | 9 |
| Connectivity | 9 |
| Performance | 10 |
| Security | 10 |
| Form Factor | 10 |
| Exceptional Ease of Use | 10 |
| Countertop Performance in a Hand-Over Design | 11 |
| True Multi-Application Capability | 11 |
| | |
| CHAPTER 2 | |
| Setup | |
| Selecting Unit Location | 13 |
| Ease of Use | 13 |
| Environmental Factors | 14 |
| Electrical Considerations | 14 |
| PIN Protection Measures | 14 |
| Unpacking the Shipping Carton | 15 |
| Periodic Inspection | 16 |
| Examining Unit Features | 17 |
| Front Panel | 17 |
| Connection Ports | 18 |
| Establishing Communication | 20 |
| Connecting by Telephone Line | 20 |
| Connecting by Ethernet Cable | 21 |
| Loading a Paper Roll in the Printer | 21 |
| Installing or Replacing MSAM Cards | 23 |
| Connecting Optional Devices | 24 |
| Optional Device Connections | 25 |
| Connecting to a PC | 25 |
| Connecting to ECRs | 26 |
| Connecting to PINpads | 26 |
| Connecting the Terminal Power Pack | 27 |
| Installing Privacy Shield | 29 |
| Using the Contactless Reader | 31 |
| Using the Smart Card Reader | 32 |
| Using the Magnetic Card Reader | 33 |
| | |
| CHAPTER 3 | |
| Specifications | |
| Technical Specifications | 35 |

| | | |
|-------------------------------------|--|----|
| | Unit Power Requirements | 35 |
| | Temperature | 35 |
| | Memory | 35 |
| | Magnetic Stripe Card | 35 |
| | Smart Card Reader | 35 |
| | CTLS Function | 35 |
| | SAM Requirements | 36 |
| | Communication | 36 |
| | Display | 36 |
| | Thermal Printer | 36 |
| | MOD 10 RS-232 + USB/Mini-USB Multi-Communication Dongle | 36 |
| | V200c Plus and V400c Plus Additional Features | 36 |
| CHAPTER 4 | | |
| Maintenance and Cleaning | Maintenance | 37 |
| | Cleaning | 37 |
| | Cleaning the Terminal | 37 |
| | Cleaning the MSR | 38 |
| | Cleaning the SCR | 38 |
| | Additional Safety Information | 38 |
| CHAPTER 5 | | |
| Service and Support | Service Returns | 39 |
| | Accessories and Documentation | 40 |
| | Connection Cables | 41 |
| | Multi-Connection Dongles and Cables | 41 |
| | Power Supplies | 41 |
| | Accessories | 41 |
| | Documentation | 41 |
| CHAPTER 6 | | |
| Troubleshooting Guidelines | Blank Display | 43 |
| | Terminal Does Not Dial Out | 43 |
| | Printer Paper Jam | 44 |
| | Keypad Does Not Respond | 44 |
| | Peripheral Device Does Not Work | 45 |
| | Transactions Fail To Process | 45 |
| | Printer Does Not Print | 46 |
| | Terminal Display Does not Show Correct or Readable Information | 46 |
| CHAPTER 7 | | |
| Port Pinouts | Port Pinout Definitions | 47 |
| | Ethernet Port (LAN) | 47 |
| | Multi-Communication Port (COM1) | 47 |
| | Telco Port | 47 |
| | USB Pinout (Host Port) | 48 |
| | RS-232 Port (COM1) | 48 |
| | USB Pinout | 48 |
| | USB Mini-B Pinout | 49 |
| APPENDIX A | | |
| Caution and Warning Messages | Caution and Warning Messages | 51 |



This guide is the primary source of information for setting up and installing V200c and V400c terminals.

Audience

This guide describes the card reader’s features, and provides the basic information for its installation and configuration.

Organization

This guide is organized as follows:

[Chapter 1, Device Overview](#). Provides an overview of the device.

[Chapter 2, Setup](#). Explains setup and installation of the device, selecting a location, and establishing connections with other devices.

[Chapter 3, Specifications](#). Discusses the power requirements and dimensions of the device.

[Chapter 4, Maintenance and Cleaning](#). Explains maintenance of the device.

[Chapter 5, Service and Support](#). Provides information on contacting your Verifone service provider and information on how to order accessories or documentation from Verifone.

[Chapter 6, Troubleshooting Guidelines](#). Provides troubleshooting guidelines should you encounter a problem with unit installation and configuration.

[Chapter 7, Port Pinouts](#). Shows the different pinout settings for ports on the V200c and V400c.

[Appendix A, Caution and Warning Messages](#). Shows the UL/cUL certification-compliant translations of all Warning and Caution messages in this installation guide.

Related Documentation

To learn more about the card reader and controller device, refer to the following set of documents and their associated Verifone Part Numbers (VPNs).

| | |
|---|-------------------|
| <i>V200c Certifications and Regulations Sheet</i> | VPN DOC420-001-EN |
| <i>V200c Quick Installation Guide</i> | VPN DOC420-002-EN |
| <i>V400c Certifications and Regulations Sheet</i> | VPN DOC425-001-EN |
| <i>V400c Quick Installation Guide</i> | VPN DOC425-002-EN |
| <i>V200c Reference Guide</i> | VPN DOC420-004-EN |



Conventions and Acronyms

This section describes the conventions and acronyms used in this guide.

Document Conventions

Various conventions are used to help you quickly identify special formatting. [Table 1](#) describes these conventions and provides examples of their use.

Table 1 Document Conventions

| Convention | Meaning | Example |
|---|--|---|
| Blue | Text in blue indicates terms that are cross referenced. | See Conventions and Acronyms . |
|  | The pencil icon is used to highlight important information. | If exchanging cables, use a Verifone-approved cable. |
|  | The caution symbol indicates possible hardware or software failure, or loss of data. | Using an incorrectly rated power supply can damage the unit or cause it to malfunction. |
|  | The lightning symbol is used as a warning when bodily injury might occur. | For safety, do not string cables or cords across a walkway. |

Acronym Definitions

Various acronyms are used in place of the full definition. [Table 2](#) presents acronyms and their definitions.

Table 2 Acronym Definitions

| Acronym | Definitions |
|---------|---------------------------------------|
| COM | Communications port |
| CTLS | Contactless |
| EMV | Europay, MasterCard, and Visa |
| ETH | Ethernet |
| HW | Hardware |
| I/O | Input/Output |
| ITP | Internal thermal printer |
| LCD | Liquid crystal display |
| LPS | Lines per second |
| MSAM | Micromodule-Size Secure Access Module |
| MSR | Magnetic-stripe card reader |
| PCI | Payment Card Industry |
| PIN | Personal Identification Number |
| POI | Point of Interaction |

Table 2 **Acronym Definitions** (continued)

| Acronym | Definitions |
|---------|--------------------------------------|
| PTS | PIN Transaction Security |
| QVGA | Quarter Video Graphics Array |
| RJ45 | Registered Jack 45 modular connector |
| SAM | Secure Access Module |
| SC | Smart card |
| SCR | Smart card reader |
| SD | Secure Digital |
| SDA | Static Data Authentication |
| SDHC | Secure Digital High Capacity |
| SIM | Subscriber Identity Module |
| SMA | SubMiniature version A connector |
| TFT | Thin-film transistor |
| TLS | Transport Layer Security |
| UI | User interface |
| USB | Universal Serial Bus |

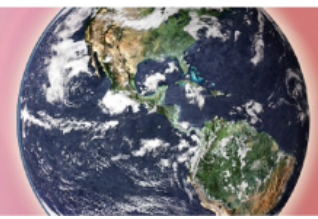

Device Overview

This chapter provides a brief description of V200c and V400c terminals.

These devices offer several communication options, enhanced display, increased processing power and two USB peripheral ports.

V200c and V400c terminals use a robust, sleek, and highly functional design.

Features and Benefits

Each V200c and V400c is an all-in-one countertop payment system that provides magnetic-stripe card reader (MSR) and smart card (SC) payment processing with a fast internal thermal printer (ITP). The V200c and V400c has a clear color TFT LCD display and the V400c adds touchscreen capability. The V200c CTLS, V200c Plus, V400c, and V400c Plus offer quick contactless (CTLS) functionality.

NOTE

Verifone ships variants of the V200c and V400c terminals for different markets. Your terminal may have different features described in this section.

Connectivity

- 2 SAM ports (standard size)
- Multi-Communication port
- Host USB port
- Client USB port
- Telco port (56K modem)
- Ethernet Port
- V200c Plus and V400c Plus: Bluetooth and Wi-Fi

NOTE

The connectivity ports are easily accessible from the underside of the terminal.

- Performance**
- 600 MHz, 32-bit processor (CPU)
 - Increased memory:
 - V200c CTLS, V200c and V400c: 128MB RAM, 256MB Flash
 - V200c Plus and V400c Plus: 512MB RAM, 512MB Flash
 - Full-color screens
 - V200c: 2.8-inch QVGA LCD (240 x 320)
 - V400c: 3.5-inch (320 × 480) HVGA capacitive color touchscreen
 - Backlit keypad with tactile and audible feedback

- Security**
- PCI-approved for debit and other PIN-based transactions:
 - V200c terminals are PCI PTS POI v4.x and PCI PTS POI v5.x approved
 - V400c terminals are PCI PTS POI v5.x approved
 - EMV L1 Type Approval (contact and contactless)
 - Tamper-resistant construction, TLS protocols, and VeriShield file authentication
 - Supports VeriShield Protect encryption implementations

- Form Factor**
- V200c and V400c terminals are ergonomically designed to fit both the traditional countertop and hand-over models.

- Exceptional Ease of Use**
- Flexible UI capabilities:
 - V200c: 4-way navigation button with two selection keys for UI access
 - V400c: on-screen navigation and selection
 - Contactless functionality offers a convenient payment option for consumers.
 - Bold design is sleek, stylish, and lightweight for conveniently handing the terminal to the consumer for PIN entry or other input.
 - Large backlit display with backlit keypad, and extra-size menu prompts, simplify training and reduce help desk calls.
 - Multiple font-capable integrated thermal printer simplifies paper loading and reduces paper jams. Uses 57 mm wide x up to 40 mm diameter paper rolls and prints at 30 lines per second (LPS).
 - Triple-track, high-coercivity card reader handles most magnetic stripe cards.

Countertop Performance in a Hand-Over Design

- 32-bit processing and multi-tasking capability ensures fast processing of payment, payment-related, and value-added applications.
- Exceptional display and printer graphics-handling capabilities that quickly render logos, graphical fonts, and character-based languages.
- V200c and V400c terminals ensure uncompromising reliability from Verifone, the worldwide leader in e-payment.

True Multi-Application Capability

- V200c CTLS, V200c and V400c terminals offer 256MB while the V200c Plus and V400c Plus terminals offers 512MB of dynamic memory allocation for the operating system, which supports multiple applications on a single terminal.
- Primary smart card reader and the MSAMs safeguard sensitive financial data and support multiple smart card schemes.
- V200c and V400c units are certified for ISO7816-3, ISO7816-10 and EMV4.3 standards for smart card solutions.
- VeriShield security architecture meets published specifications for PCI PTS POI and provides sophisticated file authentication to prevent execution of unauthorized software on V200c and V400c devices.
- Biometrics and Barcode reader support is available via the MOD 10 RS-232 + USB/Mini-USB Multi-Communication dongle.



Setup

This chapter describes the setup procedures for V200c and V400c terminals under the following sections:

- Selecting Unit Location
- Unpacking the Shipping Carton
- Examining Unit Features
- Establishing Communication
- Loading a Paper Roll in the Printer
- Installing or Replacing MSAM Cards
- Connecting Optional Devices
- Connecting the Terminal Power Pack
- Installing Privacy Shield
- Using the Contactless Reader
- Using the Smart Card Reader
- Using the Magnetic Card Reader



Verifone ships variants of V200c and V400c terminals for different markets; your terminal may have a slightly different configuration.

This *Installation Guide* documents features for both V200c and V400c terminals.

Selecting Unit Location

Use the following guidelines when selecting a location for your device.

- Ease of Use**
- Select a location convenient for both merchant and cardholder.
 - Select a flat support surface, such as a countertop or table.
 - Select a location near a power outlet and a network, telephone, or modem line connection.
 - For safety, do not string the power cord in a walkway or place it across a walkway on the floor.

Environmental Factors

- The unit must be used in an attended environment.
- Do not use the terminal where there is high heat, dust, humidity, moisture, or caustic chemicals or oils.
- Keep the terminal away from direct sunlight and anything that radiates heat, such as a stove or motor.
- Do not use the terminal outdoors.



The terminal is not waterproof or dustproof, and is intended for indoor use only. Any damage to the unit from exposure to rain or dust may void any warranty.

Electrical Considerations

- Avoid using terminals during electrical storms.
- Place the unit 10 cm away from metallic objects to avoid interference with the CTLS field.
- Avoid locations near electrical appliances or other devices that cause excessive voltage fluctuations or emit electrical noise (for example, air conditioners, electric motors, neon signs, high-frequency or magnetic security devices, or computer equipment).
- Do not use the terminal near water or in moist conditions.

PIN Protection Measures

Several techniques can be employed to provide for effective screening of the PIN entry keypad during the PIN entry process. These methods would typically be used in combination, though in some cases a method might be used singly.

- Position V200c and V400c terminals on the check-stand in such a way as to make visual observation of the PIN entry process infeasible. Examples here include:
 - Visual shields designed into the check-stand. These shields may be solely for shielding purposes, or may be part of the general check-stand design.
 - Position the V200c and V400c so that it is angled in such a way that PIN spying is difficult.
- Install V200c and V400c terminals on adjustable stands that allow consumers to swivel the terminals sideways and/or tilt forwards/backwards to a position that makes visual observation of the PIN entry process difficult.
- Position in-store security cameras so that the PIN entry keypad is not visible.
- Install the optional privacy shield (see [Installing Privacy Shield](#)).

The following table shows the combinations of methods that must be used when installing V200c and V400c terminals to protect the cardholder's PIN during PIN entry.

Table 1 PIN Entry Protection Measures

| Method | Observation Corridors | | | |
|------------------------------|--|---|--------------------------|--|
| | Cashier | Customer Queue | Customers Elsewhere | On-Site Cameras |
| Countertop with Swivel Stand | No Action Needed | Customer positions V200c and V400c | No Action Needed | Do not install within view of cameras |
| Countertop without stand | Position the V200c and V400c to face away from the cashier. Use signage to block cashier's view. | Position the V200c and V400c between customer and the next in queue. Install the optional privacy shield. | Privacy Shield Installed | Do not install within view of cameras. |



A swivel stand gives the cardholder freedom to position the terminal to optimize their viewing angle. If you are installing a swivel stand, you must include prompts in your application directing the cardholder to position the V200c and V400c terminals strategically to restrict the view of other customers.

Additionally, you may wish to implement the following to further increase security during PIN entry.

- Offer PIN security literature at the point of sale
- Use signage to limit the view of V200c and V400c terminals to just that of the cardholder

Unpacking the Shipping Carton

Open the shipping carton and carefully inspect its contents for possible tampering or shipping damage. V200c and V400c terminals are secure products and any tampering may cause the devices to cease functioning properly.

- 1 Validate the authenticity of the sender by verifying the shipping tracking number and other information located on the product order paperwork.
- 2 Remove and inspect the following items:
 - Terminal
 - Power pack
 - Telephone line cord
 - Paper roll



Verifone ships variants of the V200c and V400c terminals for different markets. Your terminal may have different accessories described in this section. Refer to [Accessories and Documentation](#) for more information about related accessories.

- 3 Remove all plastic wrapping from the terminal and other components.
- 4 Remove the clear protective film from the display.
- 5 Save the shipping carton and packing material for future repacking or moving of the device.

WARNING

Do not use a unit that has been tampered with or otherwise damaged. This unit comes equipped with tamper-evident labels. If a label or component appears damaged, immediately notify the shipping company and your Verifone representative or service provider.

Periodic Inspection

Periodically inspect V200c and V400c terminals for possible tampering. Signs of tampering include:

- Wires protruding out of the device
- Foreign objects inserted into the smart card slot or magnetic stripe slot
- Signs of damage to the tamper-evident labels
- A Tamper Warning message on the device display

If any device is found to have been tampered with, please remove it from service immediately, keep it available for potential forensics investigation, and notify your company security officer and your local Verifone representative or service provider. For contacting Verifone, please see [Service and Support](#).

For terminals equipped with a privacy shield, perform daily inspections to ensure that the privacy shield is installed and has not been removed.

Examining Unit Features

Before you continue the installation process, review the features of the device (see Figure 1).

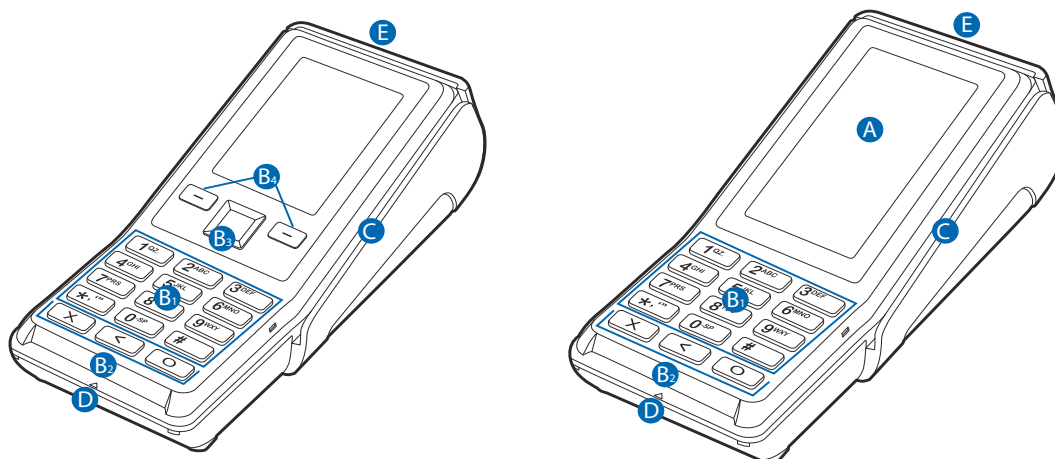

Figure 1 V200c and V400c Front Views

Front Panel The front panel includes the following features:

- A** A terminal display, backlit LCD screen.
 - On CTLS-enabled units, the screen also acts as the tapping area for contactless transactions.
 - V400c terminals have a capacitive color touchscreen LCD.
- B** These terminals have several sets of keys:
 - B1** A backlit 12-key keypad
 - B2** Three color-coded function keys below the keypad (icons at right; from left to right: CANCEL, BACKSPACE/CLEAR, ENTER)

The V200c has physical navigation and selection keys:

 - B3** 4-way navigation button centered at the top of the keypad, below the LCD screen
 - B4** Two selection keys on the left and right side of the navigation button

The V400c terminal uses on-screen navigation and selection keys.
- C** A magnetic card reader, built into the right side. The icon shows the proper swipe direction, with the stripe down and facing inward, toward the keypad.
- D** A smart card reader, built into the front of the terminal. The icon indicates proper card position and insertion direction.
- E** The internal thermal printer opens toward the rear of the unit.

Connection Ports Turn the terminal upside down and remove the rear cover to view the connection ports. Notice that the ports are recessed. Different ports provide connections to communications lines, optional peripheral devices, and the power supply.

Figure 2 shows how to open the rear cover of the V200c and V400c device.

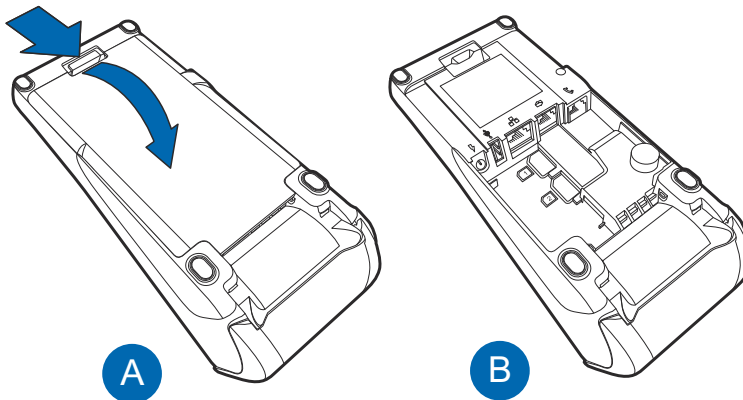

Figure 2 Opening the Rear Cover

Figure 3 shows the power, communications and connection ports for V200c and V400c devices.

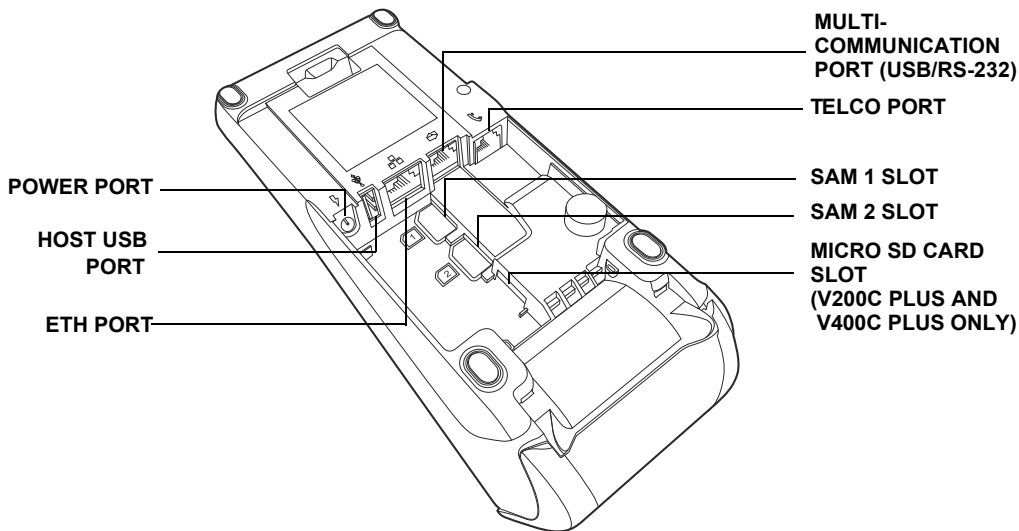

Figure 3 Power and Connection Ports



Do not connect the terminal to the power supply until all the peripherals are connected.

Using the connection ports The connection ports offer multiple connectivity for the V200c and V400c terminal. Please refer to the following list of peripheral devices for the connectivity options.



Verifone ships variants of the V200c and V400c terminals for different markets. Your terminal may have different features described in this section.

- Host USB Port:
 - PIN Pads
 - Barcode readers
 - Biometric readers
 - USB flash disk
 - USB keyboards
- Ethernet Port: Ethernet cable to router, hub or switch
- Multi-Communication Port (USB/RS-232):
 - PIN Pads
 - Computers
 - ECRs
 - Check readers
 - CTLS readers
 - Biometric readers
 - Barcode readers
 - Keyboards
- Telco Port: Telephone line with 56K modem
- The MOD 10 RS-232 + USB/Mini-USB Multi-Communication dongles (VPN CBL420-002-01-A and CBL420-002-02-A) support the following:
 - PIN Pads
 - Computers
 - ECRs
 - Check readers
 - CTLS readers
 - Biometric readers
 - Barcode readers
 - Keyboards

NOTE



The Multi-Communication port supplies 11.6 V / 500 mA to power accessories (PIN pads and powered RS-232 devices). It is SW configurable to Host or Client and supplies 5 V, 500 mA to external USB devices.

For information on how to attach peripheral devices, see [Connecting Optional Devices](#).

Establishing Communication

You can connect V200c and V400c terminals to a telephone line and/or Ethernet cable. On V200c and V400c Plus units, you can also connect via Wi-Fi or Bluetooth.

Connecting by Telephone Line

Connect the telephone cord to the communication port on the terminal, then route it directly to a telephone wall jack (see [Figure 4](#)). This is a direct connection and the line is dedicated to the terminal.

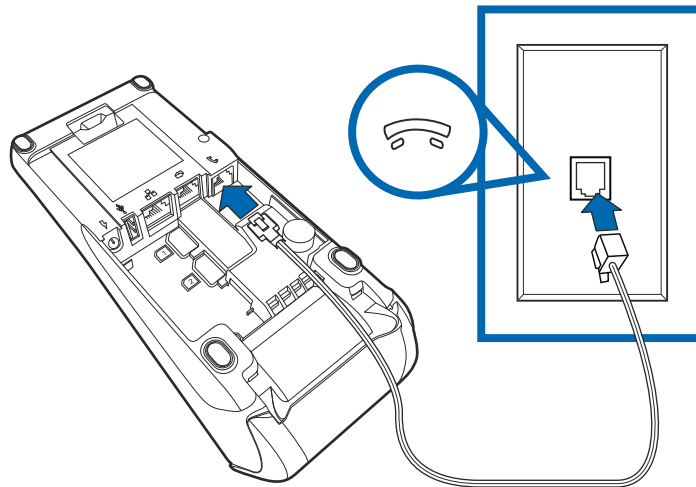

Figure 4 Direct Telephone Connection

WARNING



To reduce the risk of fire, use only No. 26AWG or larger UL Listed or CSA Certified Telecommunication Line Cord.

Connecting by Ethernet Cable

Connect the Ethernet cable to the ETH port on the terminal, then route it directly to a network jack (see Figure 5). This is a direct connection to your network.

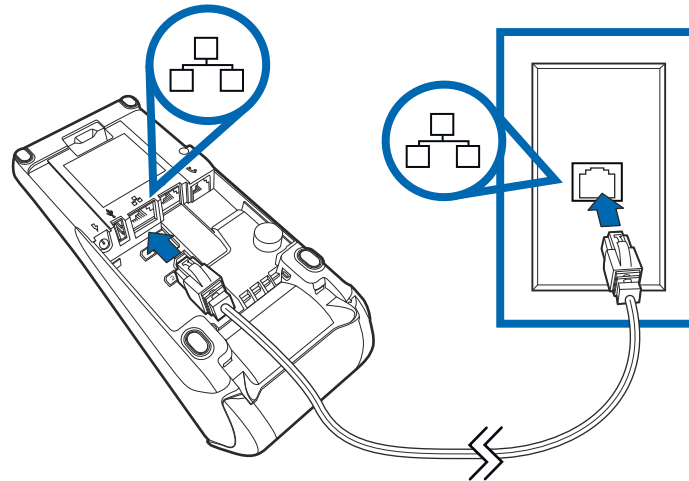

Figure 5 Ethernet Connection

Loading a Paper Roll in the Printer

Before you can process transactions that require a receipt or record, you must install paper in the printer.

V200c and V400c terminals use rolls of 57 mm wide x up to 40 mm diameter rolls of single-ply, thermal sensitive paper.

A pink out-of-paper indicator line appears on the edge of the paper before the end of the roll. After this line appears, there is enough paper remaining on the roll to conclude at least one more transaction.



Poor-quality paper can jam the printer and create excessive paper dust. To order high-quality Verifone paper, refer to [Accessories and Documentation](#).

Store thermal paper in a dry, dark area. Handle thermal paper carefully: impact, friction, temperature, humidity, and oils affect the color and storage characteristics of the paper.

Never load a roll of paper with folds, wrinkles, tears, or holes at the edges.



V200c and V400c terminals use the same paper and printers.

The following illustrations show V200c examples, but the same paper-loading process works for V400c terminals.

- Installing a paper roll** 1 Hook your finger under the latch and lift up to swing the paper roll cover open (see Figure 6).

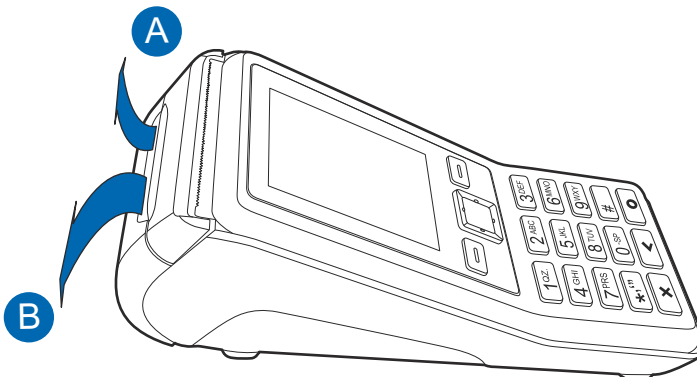

Figure 6 Opening the Printer Cover

- 2 Remove any partial roll of paper in the printer tray by lifting it up.
- 3 Loosen the glued leading edge of the new paper roll or remove the protective strip. Unwind the paper roll past any glue residue.
- 4 Hold the roll so the paper feeds from the *bottom* of the roll.
- 5 Drop the paper roll into the printer tray.

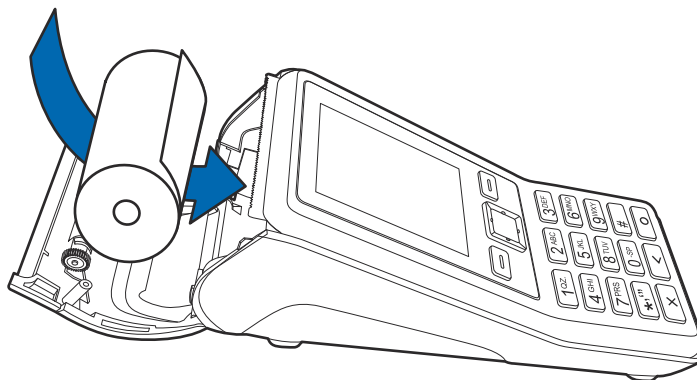

Figure 7 Loading Paper Roll

- 6 Pull paper up past the glue residue.

- 7 Close the paper roll cover by gently pressing directly on the cover until it clicks shut, allowing a small amount of paper past the glue residue to extend outside the printer door (see [Figure 8](#)).



To prevent the paper roll cover from damaging the print roller, always gently press down on the printer dust cover to close it.

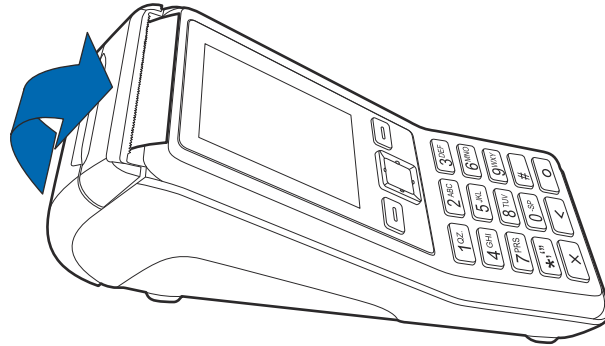

Figure 8 Closing Paper Roll Cover

- 8 Tear the paper off against the serrated strip.

NOTE



For paper ordering information, refer to [Accessories and Documentation](#).

Installing or Replacing MSAM Cards

When you first receive your terminal, you may need to install one or more MSAM cards or you may need to replace old cards.



Observe standard precautions when handling electrostatically sensitive devices. Electrostatic discharges can damage this equipment. Verifone recommends using a grounded anti-static wrist strap.

NOTE



Verifone ships variants of the V200c and V400c terminals for different markets. Your terminal may have different features described in this section.

Installing or replacing MSAMs

- 1 Remove the power pack from the power outlet.
- 2 Place the terminal upside down on a soft, clean surface to protect the display from scratches.

- 3 Press the unlocking button and then lift the rear cover to access the MSAM card slots.

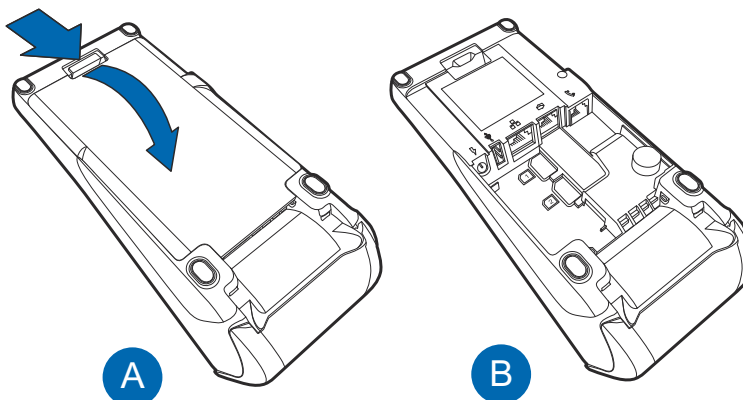

Figure 9 Opening the V200c and V400c Rear Cover

- 4 Remove any previously installed MSAM cards by sliding the card out from the cardholder.
- 5 Install an MSAM card by carefully sliding it into the slot until it is fully inserted.

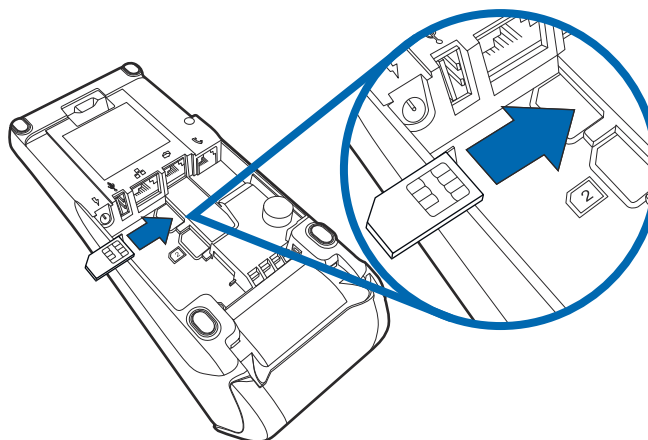

Figure 10 Installing an MSAM Card

- 6 Replace the terminal rear cover.

Connecting Optional Devices

V200c and V400c devices support multiple peripheral devices designed for use with electronic point-of-sale terminals.



CAUTION Before connecting any peripheral device, remove the power plug from the terminal. Reconnect the power cord only after you are finished connecting the peripheral device(s). For complete information about peripheral installation and use, refer to the user documentation supplied with those devices.

Different terminals support different devices, so for more information about optional devices, please contact your Verifone distributor.

You can connect several devices to V200c and V400c terminals. For reference, see [Using the connection ports](#) for the list of devices you can connect to the V200c and V400c terminal.

You can use the MOD 10 RS-232 + USB/Mini-USB Multi-Communication dongle (VPN CBL420-002-01-A and CBL420-002-02-A) as a PIN pad port or an RS-232 port, depending on the power source available.

NOTE



Make sure you replace the rear cover when all cables are installed. This provides some protection to the cables and connectors. Do not carry the terminal by the installed cables or pull the terminal about the by the cables. This may cause a cable to be removed or damage the cables.

CAUTION



Some devices (ECRs and some PIN pads) require a separate power source. Before connecting to any device, remove the power cord from the unit.

Contact your Verifone representative or visit the online store at www.store.verifone.com for information on these devices.

Connecting to a PC Figure 11 shows how to connect the V200c and V400c device to a computer via the Multi-Communication port using the MOD 10 RS-232 + Mini-USB Multi-Communication dongle (VPN CBL420-002-02-A).

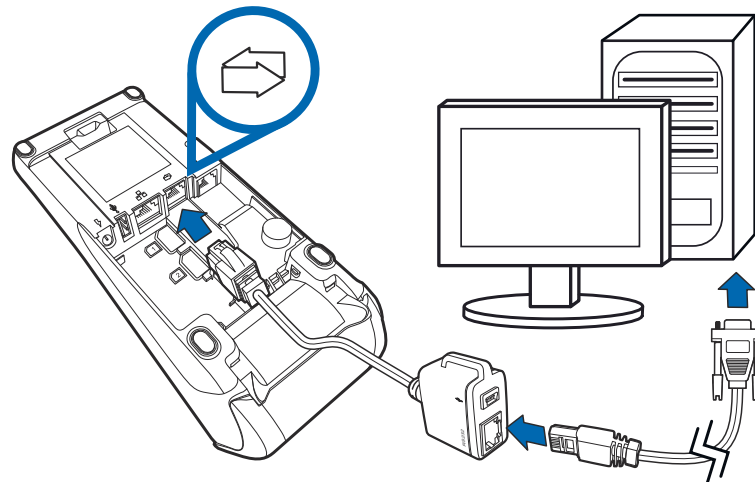

Figure 11 Sample PC Connection

Connecting to ECRs V200c and V400c terminals support electronic cash registers (ECRs).

Figure 12 shows how to make a peripheral connection to the Multi-Communication port using the MOD 10 RS-232 + USB Multi-Communication dongle (VPN CBL420-002-01-A)

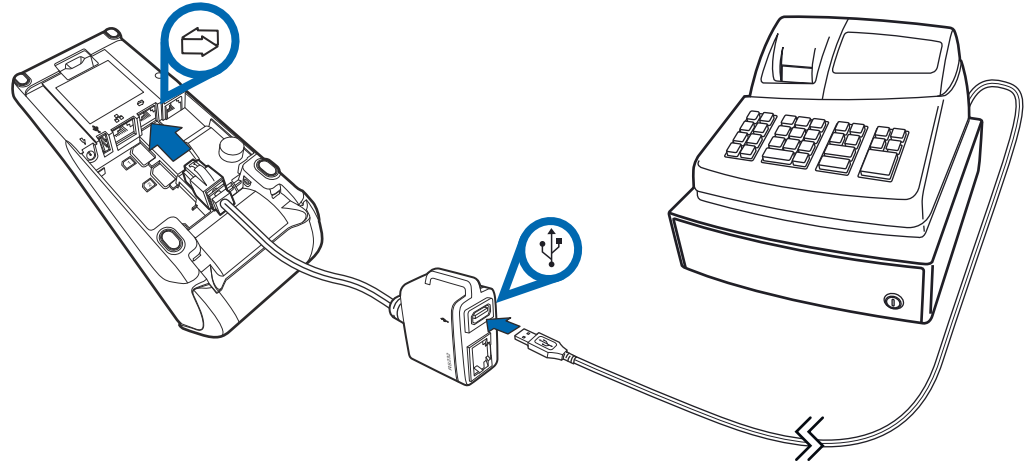

Figure 12 Sample ECR Connection

Connecting to PINpads V200c and V400c terminals also support PIN pad devices.

Figure 13 shows how to connect a PIN pad device to the host USB port on your V200c and V400c device

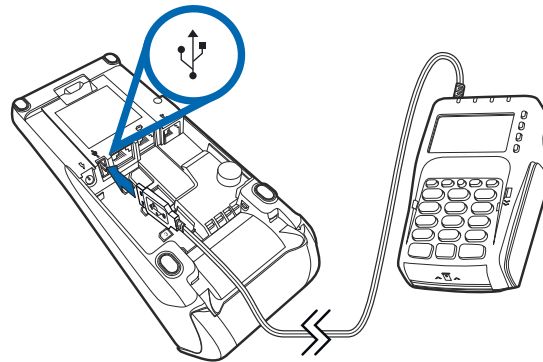

Figure 13 Sample PIN pad Connection on Host USB Port

Figure 14 shows an alternative connection of a PIN pad device to the Multi-Communication port

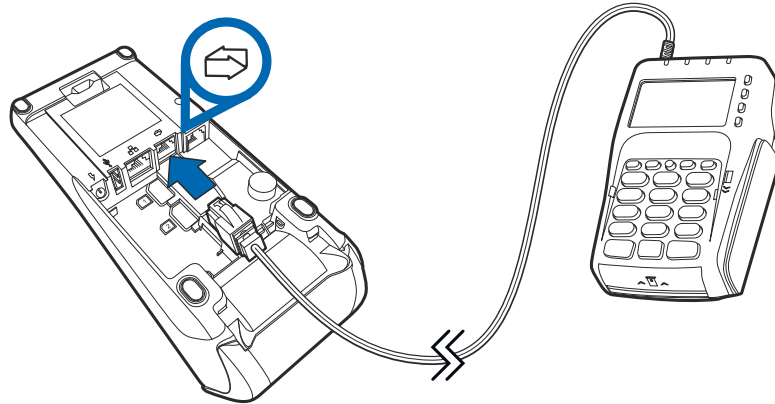

Figure 14 Sample PIN pad Connection on Multi- Communication Port

Connecting the Terminal Power Pack

After connecting optional peripherals, prepare to connect the V200c and V400c terminal to your power source.



CAUTION Using an incorrectly rated power supply may damage the terminal or cause it not to work as specified. Before troubleshooting, ensure that the power supply being used to power the terminal matches the requirements specified on the bottom of the terminal. (See [Chapter 3, Technical Specifications](#), for detailed power supply specifications.) Obtain the appropriately rated power supply before continuing with troubleshooting.



NOTE Connecting the power pack to a power source automatically turns on the terminal.

Connecting the power pack

- 1 Remove the terminal rear cover to access the power port.
- 2 Insert the round barrel connector (see Figure 15) into the power port.

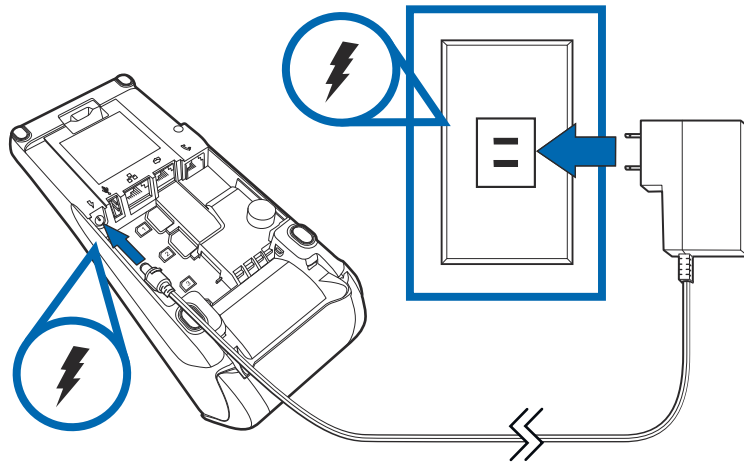

Figure 15 Power Connection

- 3 Route the cable in the direction of the arrow above the power port and sling the cable over the underside of the thermal paper container.
- 4 Close the terminal rear cover.
- 5 Plug the AC power pack into a wall outlet or powered surge protector.

WARNING



Do not plug the power pack into an outdoor outlet or operate the terminal outdoors.

Disconnecting the power during a transaction may cause transaction data files not yet stored in terminal memory to be lost.

To protect against possible damage caused by lightning strikes and electrical surges, consider installing a power surge protector.

NOTE



Verifone recommends connecting wall power in the following order:

- 1 Connect the terminal to the power supply.
- 2 Connect the power supply to the power cord (if applicable).
- 3 Connect the power cord to the wall outlet.

The terminal lights activate when the terminal has power.

If the terminal comes pre-loaded with an application, this starts after the initial Verifone copyright screen and usually displays its own copyright screen.

Locking the Power Connector

Optionally, after inserting the round barrel connector into the power port (see Figure 15), you can lock the barrel connector to keep it engaged to the terminal even when an installation tensions the power cord (see Figure 16).

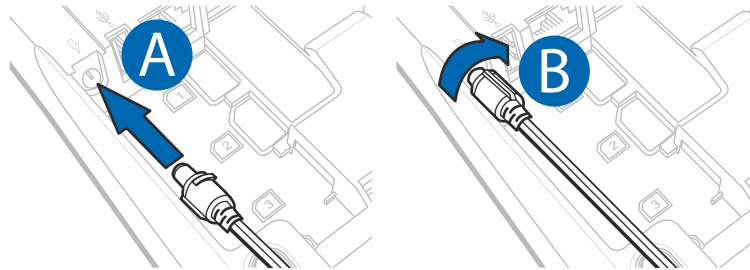

Figure 16 Locking the Power Connection

Installing Privacy Shield

The privacy shield protects the customers' PIN entry from being seen by the cashier or other customers.



V200c and V400c terminals use the same privacy shield.

The following illustrations show V400c examples, but the same privacy shield installation process works for V200c terminals.

- 1 Insert the pins into the front privacy shield slots of the V200c and V400c terminal.

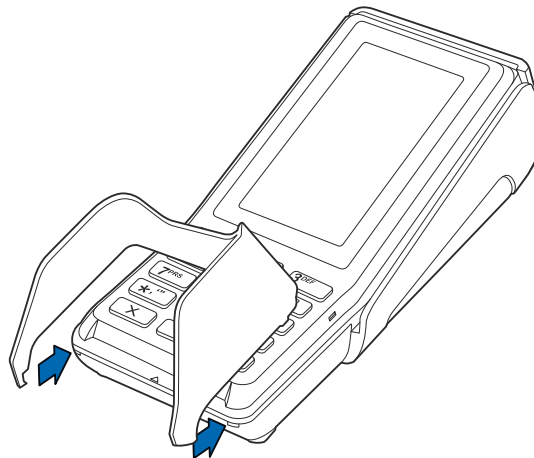

Figure 17 Inserting Front Pins of V200c and V400c Privacy Shield

- 2 Push down the rear section of the privacy shield until the side pins lock in place.

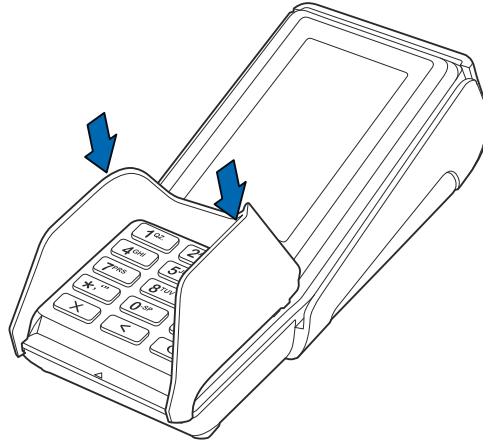

Figure 18 Snapping Side Pins in Place

- 3 Figure 19 shows an example of a terminal with a privacy shield.



Figure 19 Installed Privacy Shield

Using the Contactless Reader

V200c CTLS, V200c Plus, V400c, and V400c Plus units support CTLS functions when signaled by an application to conduct a contactless (CTLS) smart card transaction.

To perform a contactless smart card transaction

- 1 Gently tap or hold the card (within 4 cm) on the landing zone (see Figure 20).
- 2 A short beeping sound indicates a successful transaction.



Figure 20 Using a CTLS Card



NOTE Place the contactless device 10 cm away from metallic objects to avoid interference with the CTLS field.

Using the Smart Card Reader

V200c and V400c terminals support credit or debit card transactions via the smart card reader.

Smart card transaction procedures may vary from one application to another. Verify the procedure with your application provider before performing a smart card transaction.

NOTE

V200c and V400c terminals use the same smart card reader.

Figure 21 shows a V200c example, but the same process works for V400c terminals.

To conduct a smart card transaction:

- 1 Position a smart card with the contacts facing upward (see Figure 21).
- 2 Insert the smart card into the smart card reader slot in a smooth, continuous motion until it seats firmly.
- 3 Remove the card only when the application indicates the transaction is complete.

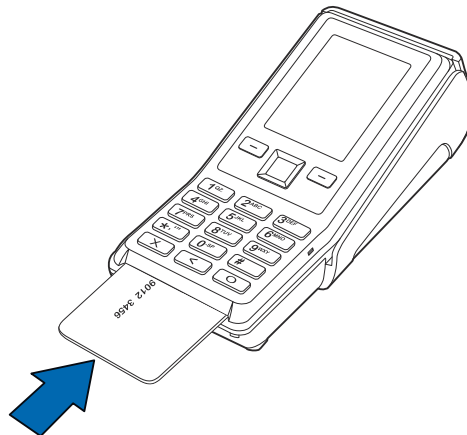

Figure 21 Inserting a Smart Card

CAUTION

Leave the smart card in the card reader until the transaction is complete.

Premature card removal will invalidate the transaction.

Using the Magnetic Card Reader

V200c and V400c terminals support credit or debit card transactions via the magnetic card reader.

NOTE

V200c and V400c terminals use the same magnetic card reader.

Figure 22 shows a V400c example, but the same process works for V200c terminals.

To conduct a credit or debit card transaction:

- 1 Position the card with the magnetic stripe oriented downward, facing the keypad.
- 2 To ensure a proper read of the magnetic stripe, swipe the card smoothly through the reader in one direction (either towards the top of the screen or the bottom of the keyboard), as shown in Figure 22.

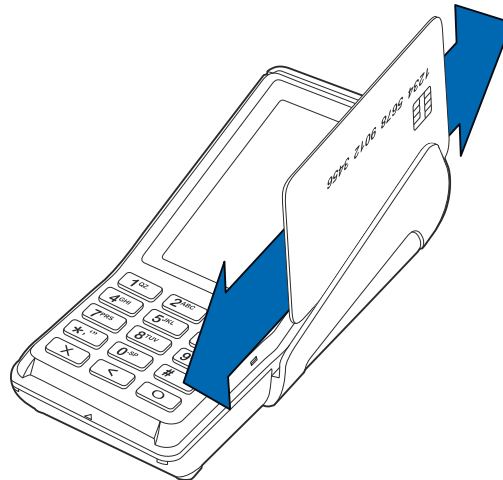

Figure 22 Using the Magnetic Card Reader

- 3 Check the screen for confirmation of a successful transaction.

SETUP

Using the Magnetic Card Reader



Specifications

This chapter discusses power requirements, dimensions, and other specifications of V200c and V400c units. Part numbers use the following conventions:

- V200c M420-xxx-11-xxx
- V200c CTLS M420-xxx-01-xxx
- V200c Plus M420-xxx-04-xxx
- V400c M425-xxx-01-xxx
- V400c Plus M425-xxx-04-xxx

Technical Specifications

Refer to the following information on the power, weight, temperature, memory, ports and other technical details about your V200c and V400c terminals.

Unit Power Requirements

- Input power rating: 11.6 V DC, 1.55 A
- External universal-input 18 W power supply, compliant with Energy Efficiency

Temperature

- Operating Environment: 0°C to +50 °C (32 °F to 122 °F)
- Non-Operating Environment:
 - V200c: -20 °C to +60°C (- 4 °F to 140 °F)
 - V400c: -20 °C to +60°C (- 4 °F to 140 °F)
- Relative humidity: 5% to 90% RH non-condensing

Memory

- 128MB DDRAM, 256MB NAND-Flash (V200c and V400c)
- 512MB DDRAM, 512MB NAND-Flash (V200c CTLS and V400c Plus)

Magnetic Stripe Card

- Triple-track
- Supports bi-directional card read, swipe speed at 10 IPS to 40 IPS

Smart Card Reader

- Non-sliding
- Card conserving plated landing contacts
- SC voltage 1.8V, 3.0V, 5.0V

CTLS Function

- V200c CTLS, V200c Plus, V400c, and V400c Plus only

- SAM Requirements**
 - 2 SAM slots
 - ID-000 format

- Communication**
 - Ethernet
 - Speed 10 Base-T /100 Base-TX
 - Compliant with IEEE802.3 LAN networks
 - Dial modem
 - V.92 standard supported, line speeds from 2400 Kbps to 56 Kbps
 - USB
 - USB 2.0 high speed
 - Supports 5 V / 600 mA to external USB device
 - Multi-Communication port
 - Supports the optional MOD 10 RS-232 + USB/Mini-USB Multi-Communication dongle

- Display**
 - V200c terminals have a 2.8-inch portrait mode transmissive TFT LCD (QVGA, 240 x 320)
 - V400c terminals have a 3.5-inch portrait mode capacitive color touchscreen LCD (HVGA, 320 x 480)
 - Software controllable back-light

- Thermal Printer**
 - Support 30 LPS for first 30 sec, and then printing speed will slow down to meet 18 W power budget
 - Supports 57 mm wide x up to 40 mm diameter paper roll
 - Out-of-Paper Sensor

- MOD 10 RS-232 + USB/Mini-USB Multi-Communication Dongle**
 - Customized extension cable providing USB host port or USB client functionality. Integrates RS-232, USB2.0 Host / Device IO ports into a 10-pin RJ45 connector. The MOD 10 RS-232 + USB/Mini-USB Multi-Communication dongle is not a standard in-box accessory.

- V200c Plus and V400c Plus Additional Features**
 - SD Memory
 - Bluetooth
 - Wi-Fi

Maintenance and Cleaning

Maintenance Treat your V200c and V400c terminals with care. They have no user-serviceable parts.

The following suggestions will help you protect your warranty coverage.

- Do not store the device in hot areas. High temperatures can shorten the life of electronic devices, damage batteries, and warp or melt certain plastics.
- Do not store the device in cold areas. When the device returns to its normal temperature, moisture can form inside the device and damage electronic circuit boards.
- Do not drop, knock, or shake the device. Rough handling can break internal circuit boards and fine mechanics.

These suggestions apply equally to your device, as well as any of its attachments or accessories. If your device is not working properly, take it to the nearest Verifone-authorized service provider for servicing or replacement.

Cleaning The following suggestions and cautions will help you keep your terminal clean.

Cleaning the Terminal To clean the device, use a clean cloth slightly dampened with water and a drop or two of mild soap. For stubborn stains, use alcohol or an alcohol-based cleaner.

CAUTION



Never use thinner, trichloroethylene, or ketone-based solvents – they can deteriorate plastic or rubber parts.

Do not spray cleaners or other solutions directly onto the keypad or device display.

Cleaning the MSR Dirt accumulation can lead to MSR reading problems unless you clean the magnetic stripe reader (MSR) on a regular basis (daily to once a week, depending on usage).

Clean the MSR using commercially available card reader cleaning cards, or using Verifone's recommended MSR-cleaning card (PN 02746-02).

NOTE



If using a commercially available cleaning card use **ONLY** an approved MSR cleaning card made specifically for POS MSR Card reader terminals or Petroleum MSR card readers.

Cleaning the SCR Do not attempt to clean the smart card reader (SCR). Doing so may void any warranty. For smart card reader service, contact your Verifone distributor or service provider.

CAUTION



If you find foreign objects in the SCR, send your terminal to a Verifone authorized repair center.

Do not use Verifone's recommended MSR-cleaning card (PN 02746-02) or commercially available card reader cleaning cards with the SCR.

**Additional
Safety
Information**

The following is additional information for your safety in using this device.

WARNING

Potentially Explosive Environments



When using the device in areas with potential risk of explosion, such as petrol stations, follow the advice of all signs and instructions. If there has been a leak, do not use this device.



Service and Support

For V200c and V400c problems, contact your local Verifone representative or service provider.

For device product service and repair information:

- USA – Verifone Service and Support Group, 1-800-834-4366, Monday - Friday, 8 A.M. - 8 P.M., eastern time
- International – Contact your Verifone representative

Service Returns

Before returning the unit to Verifone, you must obtain a Merchandise Return Authorization (MRA) number. The following procedure describes how to return one or more card reading units for repair or replacement (U.S. customers only).



International customers, please contact your local Verifone representative for assistance with your service, return, or replacement.

- 1 Gather the following information from the printed labels (see [Figure 23](#)) on the underside of each unit to be returned:
 - Product ID, including the model and part number
For example:
 - “M420-xxx-xx-xxx” and “PTID xxxxxxxx”
 - “M425-xxx-xx-xxx” and “PTID xxxxxxxx”
 - Serial number (S/N xxx-xxx-xxx)

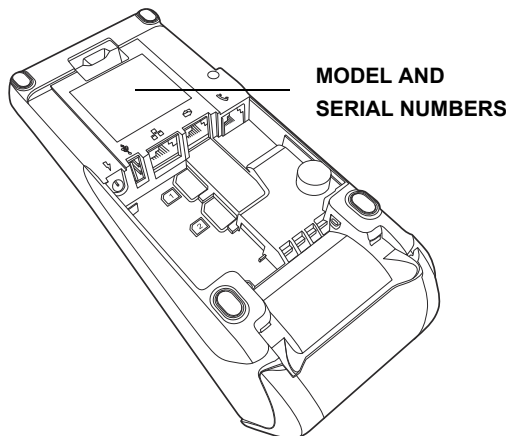

Figure 23 Information Labels on Unit

- 2 Within the United States, call Verifone toll-free at 1-800-834-4366.
- 3 Select the MRA option from the automated message. The MRA department is open Monday - Friday, 8 A.M. - 8 P.M., Eastern time.
- 4 Give the MRA representative the information gathered in [Step 1](#).
If the list of serial numbers is long, you can fax the list, along with the information gathered in [Step 1](#), to the MRA department at 1-727-953-4172 (U.S.).
 - Please address the fax clearly to the attention of the “Verifone MRA Dept.”
 - Include a telephone number where you can be reached and your fax number.
 - You will be issued MRA number(s) and the fax will be returned to you.



One MRA number must be issued for each unit you return to Verifone, even if you are returning several of the same model.

- 5 Describe the problem(s) and provide the shipping address where the repaired or replacement unit must be returned.
- 6 Keep a record of the following items:
 - Assigned MRA number(s)
 - Verifone serial number assigned to the unit you are returning for service or repair (serial numbers are located on the top of the unit, (see [Figure 23](#))
 - Shipping documentation, such as air bill numbers used to trace the shipment
 - Model(s) returned (model numbers are located on the Verifone label on the top of the unit)

Accessories and Documentation

Verifone produces accessories and documentation for the card reader. When ordering, please refer to the part number in the left column.

Verifone Online Store at www.store.verifone.com

- USA – Verifone Customer Development Center, 1-800-834-4366, Monday - Friday, 7 A.M. - 8 P.M., eastern time
- International – Contact your Verifone representative

Connection Cables

| | |
|-----------------|---|
| CBL000-016-0x-A | Cash register cable, RJ45-SUBD9f (x = length; available in 1m, 2m, 3m, and 5m) |
| CBL000-018-01-A | 3m USB slave cable, MOD10 TO USB host |
| CBL000-018-02-A | 5m USB slave cable, MOD10 TO USB host |
| CBL252-007-18-A | 2.1m cable for dial-up connections |
| CBL159-312-01-A | 2m LAN cable for Ethernet connections |
| CBL450-003-01-A | 5m LAN cable for Ethernet connections |
| CBL450-009-01-A | 3m Micro USB Cable |
| CBL450-009-02-A | 5m Micro USB Cable |

Multi-Connection Dongles and Cables

| | |
|-----------------|--|
| CBL420-002-01-A | Multi-Communication dongle (MOD 10 RS-232 + USB) |
| CBL420-002-02-A | Multi-Communication dongle (MOD 10 RS-232 + Mini-USB) |
| CBL420-007-01-A | Multi-Port Cable (MOD 10 RS-232 Ethernet, dial, serial, Micro USB, Power) |

Power Supplies

| | |
|-----------------|--|
| PWR420-001-01-C | North American Power Supply (100-240V AC, 11.6VDC/ 1.55A/18W, Peak Load 40W, Efficiency Level VI) |
| PWR420-001-02-C | European Union Power Supply (100-240V AC, 11.6VDC/ 1.55A/18W, Peak Load 40W, Efficiency Level VI) |

Accessories

| | |
|-----------------|--|
| 02746-02 | Verifone MSR-cleaning Kit |
| PPL435-007-01-A | Privacy Shield; Standard-height |
| PPR425-001-01-A | 15m Roll of Printer Paper (57mm width, 38mm diameter) |
| PPL435-013-01-A | Privacy Shield; Half-height |
| KIT425-001-01-A | Stylus and Holder to support signature capture (includes PPL435-010-01-A, PPL425-005-01-A, below) |
| PPL435-010-01-A | Stylus with Fixing Cord |
| PPL425-005-01-A | Cover with Stylus Holder |

Documentation

| | |
|-------------------|---|
| VPN DOC420-001-EN | <i>V200c Certifications and Regulations Sheet</i> |
| VPN DOC420-002-EN | <i>V200c Quick Installation Guide</i> |
| VPN DOC425-001-EN | <i>V400c Certifications and Regulations Sheet</i> |
| VPN DOC425-002-EN | <i>V400c Quick Installation Guide</i> |
| VPN DOC420-004-EN | <i>V200c Reference Guide</i> |



Troubleshooting Guidelines

This chapter lists possible malfunctions that may occur while operating V200c and V400c devices and recommends appropriate corrective actions. If the problem persists - even after performing the outlined guidelines, or if the problem is not described, contact your local Verifone representative for assistance.

NOTE

The unit comes equipped with tamper-evident labels. The terminal contains no user-serviceable parts. Do not, under any circumstance, attempt to disassemble the unit. Perform only those adjustments or repairs specified in this guide. For all other services, contact your local Verifone service provider. Service conducted by parties other than authorized Verifone representatives may void any warranty.

CAUTION

Using an incorrectly rated power supply may damage the unit or cause it to not work properly. Before troubleshooting, ensure that the power supply used to power the unit matches the specified requirements (see [Specifications](#) for detailed power supply specifications). If not, obtain the appropriately rated power supply before continuing with troubleshooting.

Blank Display

When the terminal display screen does not show correct or clearly readable information:

- Check terminal power connection.
- Remove and reapply power to the terminal.
- Check all cable connections and verify that the telephone line is properly connected.
- If the problem persists, contact your local Verifone service provider.

Terminal Does Not Dial Out

Use the following steps when the terminal does not dial out:

- If you are using a telephone connection, check if the telephone line is plugged correctly in the terminal port and in the telephone line socket.
- Check that the telephone line is working by plugging it into a working telephone and listening for a dial tone.
- Replace the telephone cable that connects the terminal with a cable you know is working correctly.
- Verify that a modem profile is present. The modem will not function without a modem profile.

- If your terminal shares the same network as your Internet, check that the Internet connection is working.
- If you are using a Wi-Fi connection, the terminal may be out of the Wi-Fi range. If possible, move the terminal closer to the Wi-Fi router.
- If your establishment uses the same modem or router to connect to a PC, you should attempt to visit a web site to verify that the router or modem is working properly.
- Check if the Wi-Fi router or modem is turned on or plugged in and connected to the telephone socket.
- Test the router or modem by connecting an analogue telephone to the phone line that the router or modem is using. Make sure there is a normal dial tone.
- Try rebooting your router, modem and/or terminal, disconnect the power cable to the terminal and router. Wait approximately 30 seconds. Allow 60 seconds for the terminal application to reboot and establish a connection with the router.
- If you are using an Ethernet connection, check if the Ethernet cable is connected to the port on the terminal and to a working network port.
- If the problem persists, contact your local Verifone service provider.

Printer Paper Jam

If paper jams inside the printer:

- 1 Open the paper roll cover.
- 2 Remove the damaged paper from the paper roll and clear the feed mechanism.
- 3 Install printer paper.
- 4 If the problem persists, it may be due to poor paper quality. Install a new roll of higher-quality paper.



Poor-quality paper may jam the printer. To order high-quality Verifone paper, refer to [Accessories and Documentation](#).

Keypad Does Not Respond

If the keypad does not respond properly:

- Check the terminal display. If it displays the wrong character or nothing at all when you press a key, follow the steps outlined in [Transactions Fail To Process](#).
- If selecting a function key does not perform the expected action, refer to the user documentation for that application to ensure you are entering data correctly.
- If the problem persists, contact your local Verifone representative.

Peripheral Device Does Not Work

If any peripheral device (PIN pad or smart card reader) does not work properly:

- Check the power cord connection to the peripheral device.
- Check that the device connected to the proper port has power and is functioning properly. If possible, perform a self-test on the device in question.
- The cable connecting the optional device to the terminal serial port may be defective. Try a different serial cable. See [Connecting Optional Devices](#).
- If the problem persists, contact your local Verifone representative.

Transactions Fail To Process

There are several reasons why the card reader may not be processing transactions. Use the following steps to troubleshoot failures.

Check the Magnetic Card Reader

- Perform a test transaction using one or more different magnetic stripe cards to ensure the problem is not a defective card.
- Ensure that you are swiping cards properly. With the card reader, the black magnetic stripe should face down.
- If possible, process a transaction manually, using an external keypad, instead of the card reader. If the manual transaction works, the problem may be a defective reader.
- If the manual transaction does not process, proceed to [Check the Telephone Line](#).
- If the problem persists, contact your local Verifone representative.

Check the Smart Card Reader

- Perform a test transaction using several different smart cards to ensure the problem is not a defective card.
- Ensure that the card is inserted correctly and that the card is not removed prematurely.
- Ensure the SAM cards are properly inserted in the cardholders and that the cardholders are properly secured (see [Installing or Replacing MSAM Cards](#)).
- If the manual transaction does not process, proceed to [Check the Telephone Line](#).
- If the problem persists, contact your local Verifone representative.

Check the Telephone Line

- Disconnect the telephone line from the terminal and connect it to a working telephone to check for a dial tone. If there is no dial tone, replace the telephone cable.
- If the problem appears to be with the telephone line, check with the party you are trying to call to see if their system is operational. If they are not

experiencing difficulties with their line, contact the telephone company and have your line checked.

- If the telephone line works, contact your local Verifone representative for assistance.

Printer Does Not Print

If the printer does not work properly:

- Check terminal power connection.
- Check if the printer is out of paper and that the roll is properly installed. Open the paper roll cover and install a new roll of printer paper or ensure that the roll is feeding from the bottom.
- Verify that the printer roller and paper roll dust cover are properly installed.
- If the problem persists, contact your Verifone distributor or service provider.

Terminal Display Does not Show Correct or Readable Information

- Connect the terminal in to a known-good power supply (if you have one) to see if this clears the problem.
- If the problem persists, contact your local Verifone representative for assistance.

Port Pinouts

Port Pinout Definitions

This section contains port pinout tables for V200c and V400c terminals.

Ethernet Port (LAN)

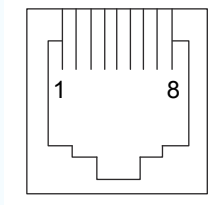
| Connector | PIN | Function | Description |
|---|-----|----------|-----------------|
|  | 1 | TXD+ | Transmit data + |
| | 2 | TXD- | Transmit data - |
| | 3 | RXD+ | Receive data + |
| | 4 | NC | No connection |
| | 5 | NC | No connection |
| | 6 | RXD- | Receive data - |
| | 7 | NC | No connection |
| | 8 | NC | No connection |

Multi-Communication Port (COM1)

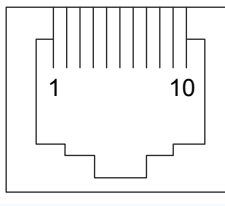
| Connector | PIN | Function | Description |
|---|-----|----------|----------------------------------|
|  | 1 | VUSB | 5 V USB power (500 mA) |
| | 2 | PORTPWR | Port power (11.6 V typ., 500 mA) |
| | 3 | NC | No connection |
| | 4 | NC | No connection |
| | 5 | GND | Power ground |
| | 6 | RXD | Receive data |
| | 7 | TXD | Transmit data |
| | 8 | NC | No connection |
| | 9 | USB0_DP | USB signal + |
| | 10 | USB0_DM | USB signal - |

Telco Port

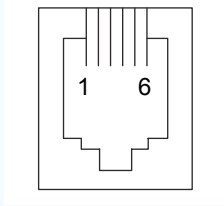
| Connector | PIN | Function | Description |
|---|-----|----------|----------------|
|  | 1 | NC | No connection |
| | 2 | NC | No connection |
| | 3 | Tip | Telephone Line |
| | 4 | Ring | Telephone Line |
| | 5 | NC | No connection |
| | 6 | NC | No connection |

USB Pinout (Host Port)

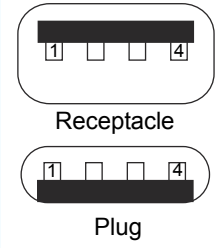
| Connector | PIN | Function | Description |
|---|-----|----------|------------------------|
|  <p>Receptacle</p> <p>Plug</p> | 1 | +5 V | 5 V USB Power (600 mA) |
| | 2 | DATA- | USB Host Signal - |
| | 3 | DATA+ | USB Host Signal + |
| | 4 | GND | USB ID pin/Ground |

RS-232 Port (COM1)

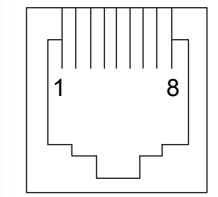
| Connector | PIN | Function | Description |
|---|-----|---------------------------|----------------------------------|
|  | 1 | Portpwr (9 to 12 V DC) | Port power (11.6 V typ., 500 mA) |
| | 2 | NC | No connection |
| | 3 | NC | No connection |
| | 4 | GND | Power ground |
| | 5 | RXD | Receive data |
| | 6 | TXD | Transmit data |
| | 7 | NC | No connection |
| | 8 | NC | No connection |



This RS-232 port is part of the RS-232 + USB/Mini-USB Multi-Communication dongles (VPN CBL420-002-01-A and CBL420-002-02-A).

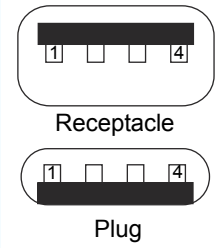

USB Pinout

| Connector | PIN | Function | Description |
|---|-----|----------|------------------------|
|  <p>Receptacle</p> <p>Plug</p> | 1 | +5 V | 5 V USB Power (500 mA) |
| | 2 | DATA- | USB Host Signal - |
| | 3 | DATA+ | USB Host Signal + |
| | 4 | GND | USB ID pin/Ground |



This USB Type-A port is part of the RS-232 + USB Multi-Communication dongle (VPN CBL420-002-01-A).

USB Mini-B Pinout

| Connector | PIN | Function | Description |
|---|-----|----------|---------------------|
|  Receptacle | 1 | 5 V 0 | 5 V USB Power |
| | 2 | DATA- | USB Device Signal - |
| | 3 | DATA+ | USB Device Signal + |
| | 4 | | |
| | 5 | GND | USB Ground |
|  Plug | | | |



This USB Mini-B port is part of the RS-232 + Mini-USB Multi-Communication dongle (VPN CBL420-002-02-A).



Caution and Warning Messages

Caution and Warning Messages

Products with UL/cUL certification include French translations of Caution and Warning notices. The following table lists all notices found in the document, their location and the equivalent French translations.

Table 1 Caution and Warning Messages

| Notice | Chapter | Page | English Text | French Text |
|---------|---------|---------|--|---|
| Caution | Setup | page 14 | The terminal is not waterproof or dustproof, and is intended for indoor use only. Any damage to the unit from exposure to rain or dust may void any warranty. | <i>Le terminal est pas étanche ou à la poussière, et est destiné à une utilisation en intérieur. Tout dommage à l'unité de l'exposition à la pluie ou à la poussière peut annuler la garantie.</i> |
| Warning | Setup | page 16 | Do not use a unit that has been tampered with or otherwise damaged. This unit comes equipped with tamper-evident labels. If a label or component appears damaged, immediately notify the shipping company and your Verifone representative or service provider. | <i>Ne pas utiliser une unité qui a été altéré ou endommagé. Cet appareil est équipé d'étiquettes inviolables. Si une étiquette ou d'un composant semble endommagé, avertissez immédiatement la compagnie de navigation et votre représentant ou du prestataire de services Verifone.</i> |
| Warning | Setup | page 18 | Do not connect the terminal to the power supply until all the peripherals are attached. | <i>Ne pas connecter le terminal à l'alimentation jusqu'à ce que tous les périphériques sont branchés.</i> |
| Warning | Setup | page 20 | To reduce the risk of fire, use only No. 26AWG or larger UL Listed or CSA Certified Telecommunication Line Cord. | <i>Pour réduire le risque d'incendie, utilisez uniquement No. 26AWG ou plus cordon certifiés CSA télécommunications UL ou.</i> |
| Caution | Setup | page 21 | Poor-quality paper can jam the printer and create excessive paper dust. To order high-quality Verifone paper, refer to Accessories and Documentation. Store thermal paper in a dry, dark area. Handle thermal paper carefully: impact, friction, temperature, humidity, and oils affect the color and storage characteristics of the paper. Never load a roll of paper with folds, wrinkles, tears, or holes at the edges. | <i>Papier de mauvaise qualité peut provoquer un bourrage et de créer excessive de poussière de papier. Pour commander - papier de haute qualité Verifone, consultez Accessoires et documentation. Gardez le papier thermique dans un endroit sombre . Manipulez le papier thermique attentivement: impact, friction, la température, l'humidité et les huiles affectent les caractéristiques de couleur et de stockage du papier. Ne jamais charger un rouleau de papier avec des plis, des larmes, ou des trous sur les bords.</i> |
| Caution | Setup | page 23 | To prevent the paper roll cover from damaging the print roller, always gently press down on the printer dust cover to close it. | <i>Pour éviter que le couvercle du rouleau de papier d'endommager le rouleau d'impression, toujours appuyez doucement sur le capot de protection de l'imprimante pour le fermer.</i> |

Table 1 Caution and Warning Messages (continued)

| Notice | Chapter | Page | English Text | French Text |
|---------|---------|---------|--|--|
| Caution | Setup | page 23 | Observe standard precautions when handling electrostatically sensitive devices. Electrostatic discharges can damage this equipment. Verifone recommends using a grounded anti-static wrist strap. | <i>Respecter les précautions standard lors de la manipulation des appareils sensibles aux décharges électrostatiques. Les décharges électrostatiques peuvent endommager cet équipement. Verifone recommande d'utiliser un bracelet anti-statique à la terre.</i> |
| Caution | Setup | page 24 | Before connecting any peripheral device, remove the power cord from the terminal. Reconnect the power cord only after you are finished connecting the peripheral device(s). For complete information about peripheral installation and use, refer to the user documentation supplied with those devices. | <i>Avant de connecter un périphérique, débranchez le cordon d'alimentation de la borne de veiller. Rebranchez le cordon d'alimentation seulement après que vous avez terminé de connecter le périphérique (s) périphérique. Pour des informations complètes sur l'installation et l'utilisation périphérique, reportez-vous à la documentation utilisateur fournie avec ces périphériques.</i> |
| Caution | Setup | page 25 | Some devices (ECRs and some PIN pads) require a separate power source. Before connecting to any device, remove the power cord from the unit. | <i>Certains appareils (ECR et quelques claviers NIP) nécessitent une source d'alimentation séparée. Avant de connecter tout périphérique, débranchez le cordon d'alimentation de l'unité.</i> |
| Caution | Setup | page 27 | Using an incorrectly rated power supply may damage the terminal or cause it not to work as specified. Before troubleshooting, ensure that the power supply being used to power the terminal matches the requirements specified on the bottom of the terminal. (See Chapter 3, Technical Specifications, for detailed power supply specifications.) Obtain the appropriately rated power supply before continuing with troubleshooting. | <i>Utilisation d'une alimentation mal classé peut endommager le terminal ou de l'empêcher de travailler comme spécifié. Avant de dépannage, assurez-vous que l'alimentation est utilisé pour alimenter le terminal correspond aux exigences spécifiées sur le fond de la borne. (Voir le chapitre 3, Caractéristiques techniques, pour les caractéristiques de l'alimentation.) Obtenir l'alimentation nominale appropriée avant de continuer avec le dépannage.</i> |
| Warning | Setup | page 28 | Do not plug the power pack into an outdoor outlet or operate the terminal outdoors. Disconnecting the power during a transaction may cause transaction data files not yet stored in terminal memory to be lost. To protect against possible damage caused by lightning strikes and electrical surges, consider installing a power surge protector. | <i>Ne pas brancher le bloc d'alimentation à une prise extérieure ou exploiter le terminal à l'extérieur. Déconnexion de l'alimentation lors d'une transaction peut entraîner des fichiers de données de transaction non encore stockées dans la mémoire terminal pour être perdu. Pour se protéger contre de possibles dommages causés par la foudre et les surtensions électriques, pensez à installer un protecteur de surtension.</i> |
| Caution | Setup | page 32 | Leave the smart card in the card reader until the transaction is complete. Premature card removal will invalidate the transaction. | <i>Laissez la carte à puce dans le lecteur de carte jusqu'à ce que la transaction est terminée. Retrait prématuré de la carte d'invalider la transaction.</i> |

Table 1 Caution and Warning Messages (continued)

| Notice | Chapter | Page | English Text | French Text |
|---------|----------------------------|---------|---|--|
| Caution | Maintenance and Cleaning | page 37 | Never use thinner, trichloroethylene, or ketone-based solvents – they can deteriorate plastic or rubber parts. Do not spray cleaners or other solutions directly onto the keypad or device display. | <i>Ne jamais utiliser de diluant, le trichloréthylène ou des solvants à base de cétone - ils peuvent détériorer les pièces en plastique ou en caoutchouc.</i> <i>Ne pulvérise pas de nettoyeurs ou d'autres solutions directement sur le clavier ou sur l'écran de l'appareil.</i> |
| Caution | Maintenance and Cleaning | page 38 | If you find foreign objects in the SCR, send your terminal to a Verifone authorized repair center. Do not use Verifone's recommended MSR-cleaning card (PN 02746-02) or commercially available card reader cleaning cards with the SCR. | <i>Si vous trouvez des objets de valeur dans le SCR envoyez votre terminal à centres de réparation autorisé Verifone.</i> <i>N'utilisez pas la carte de nettoyage MSR recommandée par Verifone (réf. 02746-02) ou les cartes de nettoyage MSR de lecteur de cartes disponibles dans le commerce avec le SCR.</i> |
| Caution | Maintenance and Cleaning | page 38 | Potentially Explosive Environments When using the device in areas with potential risk of explosion, such as petrol stations, follow the advice of all signs and instructions. If there has been a leak, do not use this device. | <i>Environnements Potentiellement Explosifs</i> <i>Lors de l'utilisation de l'appareil dans des zones à risque d'explosion, telles que les stations-service, conformez-vous à tous les panneaux et instructions. N'utilisez pas cet appareil s'il y a eu une fuite.</i> |
| Caution | Troubleshooting Guidelines | 43 | Using an incorrectly rated power supply may damage the unit or cause it to not work properly. Before troubleshooting, ensure that the power supply used to power the unit matches the specified requirements (see Specifications for detailed power supply specifications). If not, obtain the appropriately rated power supply before continuing with troubleshooting. | <i>Utilisation d'une alimentation mal classé peut endommager l'appareil ou provoquer sa ne fonctionne pas correctement. Avant de dépannage, assurez-vous que l'alimentation utilisée pour alimenter l'unité correspond aux exigences spécifiées (voir spécifications pour les caractéristiques de l'alimentation). Si non, obtenir l'alimentation nominale appropriée avant de continuer avec le dépannage.</i> |
| Caution | Troubleshooting Guidelines | page 44 | Poor-quality paper may jam the printer. To order high-quality Verifone paper, refer to Accessories and Documentation. | <i>Papier de mauvaise qualité peut provoquer un bourrage. Pour commander - papier de haute qualité Verifone, consultez Accessoires et documentation.</i> |



Verifone, Inc.
1-800-Verifone
www.verifone.com

V200c and V400c

Installation Guide

